

Waterproof Car Camera's Character:

1. 1/3 Sony CCD Sensor
2. Metal case, waterproof IP66 and vandal-proof
3. Infrared Camera with audio
4. Factory Directly Sale, competitive price
5. 0 Lux when infrared LED on
6. The lens position can be adjusted
7. 420TVL/480TVL/600TVL can be optional
8. CE FCC RoSH Approval



Waterproof Car Camera's Parameter:

Item	Parameter
Sensor	1/3"Color SONY CCD
TV System	PAL/NTSC
Picture Elements	PAL:500Hx582V NTSC: 500Hx494V
Horizontal Resolution	420TVL/480TVL/600TVL
Sensitivity	0 Lux at F1.2 (Infrared LED On)
Scanning System	625TVL, 2:1 Interlace
Synchronization	Internal
Infrared Spectrum	850nm
S/N Ratio	More than 50 dB, (AGC Off)
Auto Gain Control (AGC)	Auto
White Balance	Auto
Electronic Shutter	Auto
Back Light Compensation	Auto
Infrared LED	12pcs
Infrared LED Range	10m
Video Output	1 Vp-p, 75Ωcomposite , BNC x1
Audio Output	for Options
Mirror	for Options
Gamma Ratio	0.45
Lens	f3.6mm Standard Lens
Exterior Focus Adjustment	N/A
Lens Mount	M12XP0.5mm Thread
Pan Adjusting	N/A
Tilt Adjusting	0-60°
Power Supply	12V DC ±10%
Power Consumption	190mA
Dimensions (L X W X H)	48.5 L x 87W x 61.2H mm
Net Weight	242g
Weatherproof/Water Proof	N/A
Operating Temperature	-10°C to +50°C

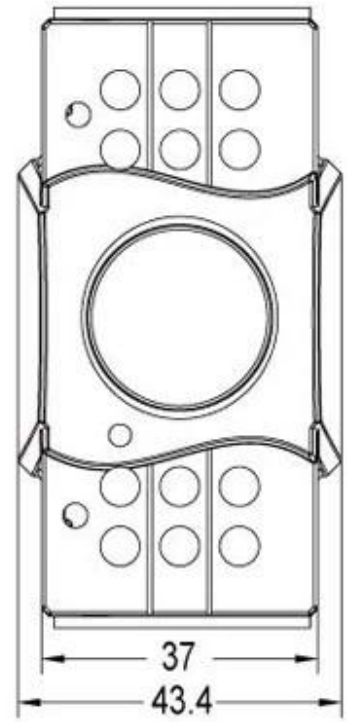
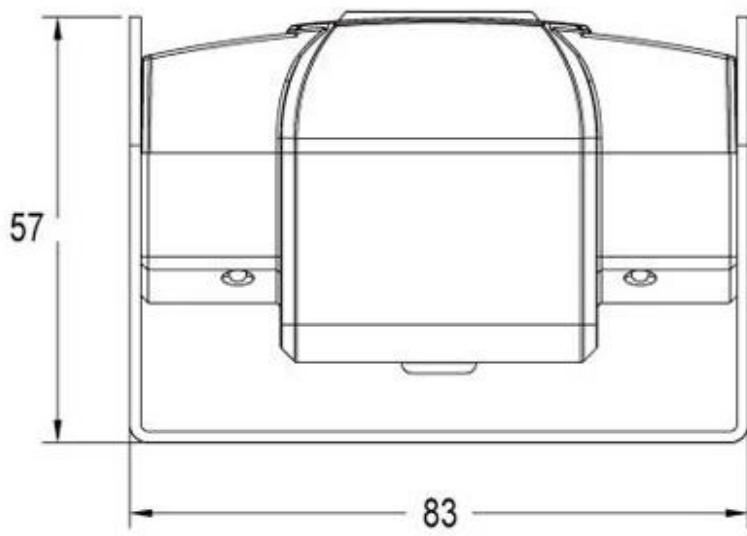

Waterproof Car Camera's Certification:



Other Car Camera for Vehicle, such as, [Car Side View Camera](#)
Waterproof Car Camera's Packing:



Waterproof Car Camera's Shipping Item:

1. FedEx/DHL/UPS/TNT for samples, Door-to-Door;
2. Delivery Time: 3-7 days for samples; negotiation for batch goods.

Payment Terms:

1. Payment: T/T, Western Union, PayPal; 30% deposits; 70% balance before delivery.
2. MOQ: 1pcs
3. Warranty : 1years
4. Package Informations: 1 pcs per box, brand packing, netural packing and customized packing

Why Choosing Us?

- 1.We are Alibaba Assessed 3 years Gold Supplier.
- 2.We are a factory manufacturing,best production capability ,best quality control, Best Service .
- 3.Inspected by the Inspection Institution of Bureau Veritas Certification.
- 4.100% QC inspection Before Shipment.
5. CE/RoHS/FCC listed,competitive price.